

THIS THIRD ARTICLE IN A SERIES ON active filters focuses on audio signal processing and amplitude control circuits. The last article, in the February 1995 issue of *Electronics Now*, page 65, discussed popular passive control networks including high- and low-pass filtering circuits. This article picks up where that article left off with a discussion of active tone-control circuits, and it goes on to explain amplitude-regulating circuits.

Active tone controls

An active tone-control circuit can be made by connecting a passive tone-control network to the negative feedback loop of a linear amplifier, typically an operational amplifier. This circuit provides signal gain rather than attenuation.

Tone-control networks can be simplified versions of Fig. 15 in the February 1995 article. However, they are more likely to be based on the alternative passive tone-control circuit shown here as Fig. 1. This circuit's performance is comparable, but requires fewer components, and it includes two linear control potentiometers.

If the input signals to the circuit in Fig. 1 are low enough so that capacitors C1 and C2 act like open circuits, the output signal amplitudes are controlled entirely by resistor R5. This occurs because resistor R6

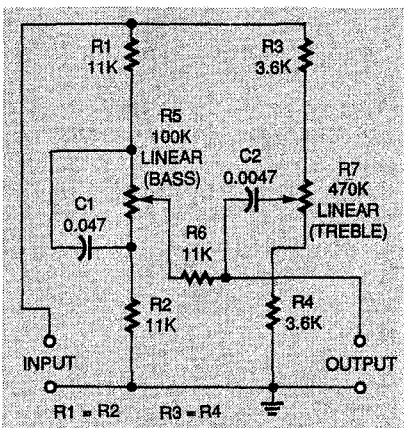
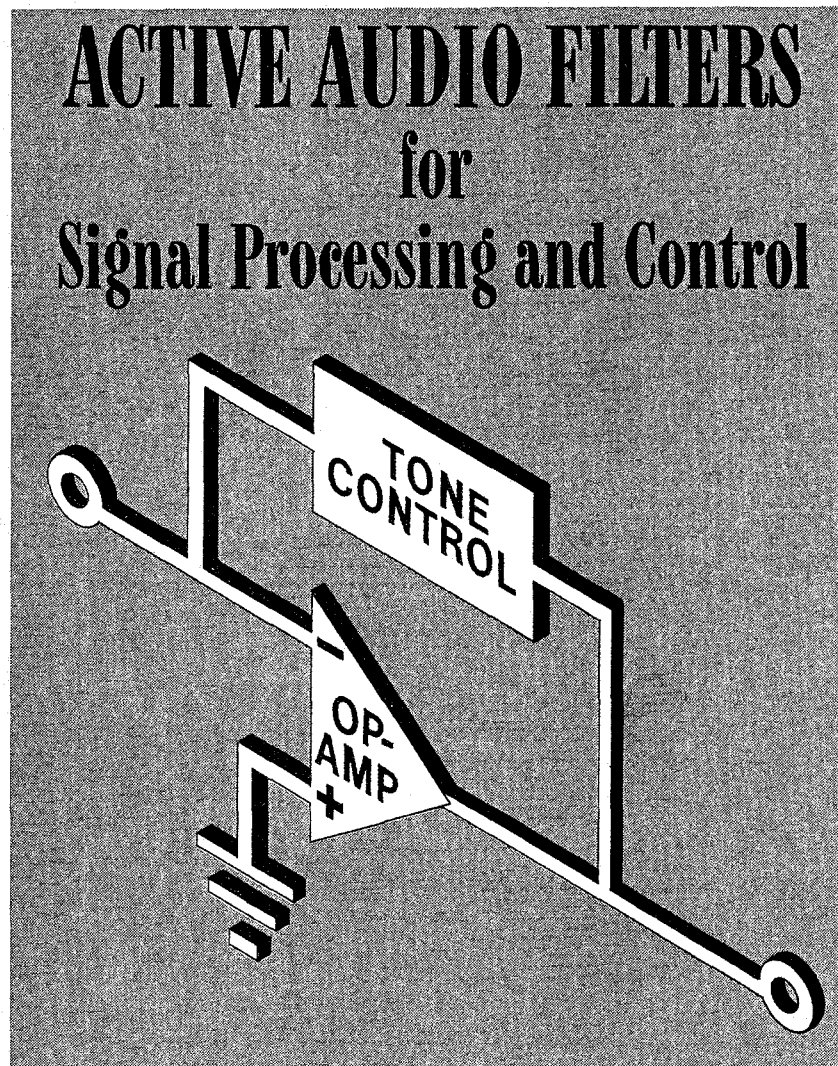

FIG. 1—ALTERNATIVE TONE-CONTROL circuit that includes two potentiometers.



Learn about active filters in audio signal processing and control, and apply that knowledge to your circuit designs

is isolated from the output by capacitor C2.

However, at input frequencies that are high enough so that the two capacitors act like short circuits, the output signal amplitudes are controlled entirely by resistor R6. In this situation, resistor R5 is short circuited by C1.

The low-frequency (*bass*) circuit cutoff is determined by the values of R1 and C1, and the high-frequency (*treble*) cutoff is determined by C2 and the values of R1 to R3.

Figure 2 illustrates how the network in Fig. 1 network is integrated into an active tone control circuit that can provide up

to 20 decibels (dB) of boost or cut to bass or treble signals.

The circuit shown in Fig. 3, although similar to that of Fig. 2, is more versatile. It has an additional filter control network that is centered on the 1-kHz *midband* of the audio spectrum. This network permits the midband to be boosted or cut by as much as 20 dB.

Graphic equalizers

The more sophisticated graphic equalizer tone-control system consists of a many parallel-connected, variable-response filters that overlap and have narrow-passbands to cover the entire audio spectrum. This cir-

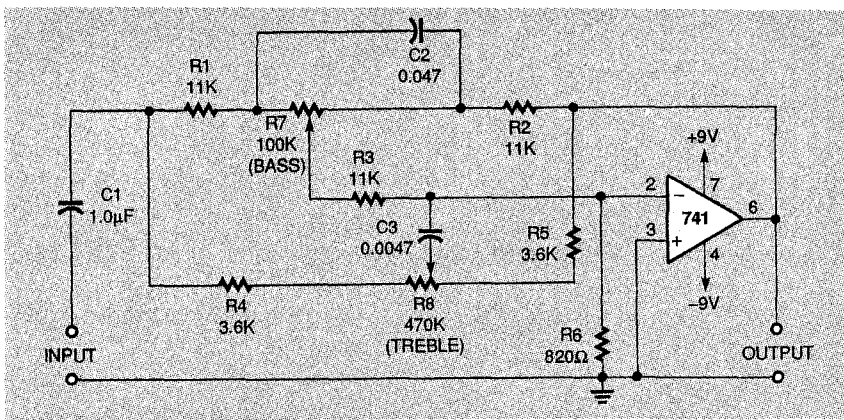

FIG. 2—ACTIVE TONE-CONTROL CIRCUIT that includes the Fig. 1 circuit.

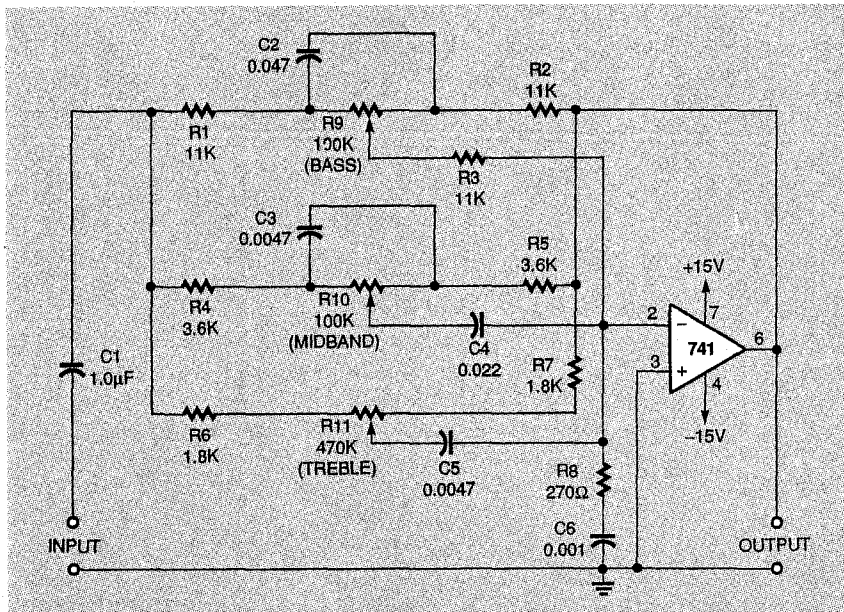

FIG. 3—THREE-BAND ACTIVE TONE-CONTROL control (bass, midband, treble).

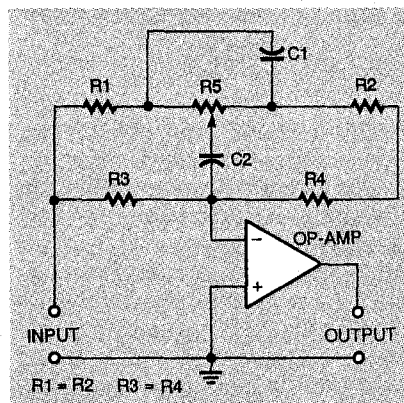

FIG. 4—TYPICAL OCTAVE (GRAPHIC) equalizer section.

cuitry permits tailoring an amplifier circuit's spectral response to suit individual needs. The filter center frequencies are typically spaced at one octave intervals. As a result, those systems are also called *octave*

are in parallel, and their outputs are summed in the output stage that includes the IC11 operational amplifier.

The operational amplifiers in this circuit can be the industry-standard LM741 or comparable dual versions such as the LM747. Stereo amplifier systems visually contain two complete circuits of the kind shown in Fig. 5.

RIAA equalization

Phonograph records are no longer the preferred media for storing and reproducing music, having been replaced years ago by tape cassettes and compact discs (CDs). Nevertheless, many people still own turntables for playing 33 RPM long-playing record (LPs) or 45 RPM records. The pickup arms of those record players include either ceramic, crystal, or magnetic cartridges and needles that are in direct contact with the grooves in the records.

The ceramic and crystal cartridges were inexpensive, but they produced large-amplitude and fairly linear outputs suitable for low-priced record players. However, magnetic cartridges were preferred for high-performance, high-fidelity stereo systems. Although their output is low, and they have nonlinear frequency response characteristics, their corrected output provides more faithful music reproduction.

The characteristics of any record playback system can be determined with a test record containing a three-decade span of sinewave tone signals with constant amplitude from 20 Hz to 20 kHz. A quality magnetic cartridge should generate a nonlinear frequency response that rises at a rate of 6 dB per octave (equal to 20 dB per decade). Thus the output signals would be weak at 20 Hz, but would be one thousand times greater (equal to +60 dB) at 20 kHz.

This nonlinear frequency response is an inherent characteristic of all magnetic pickups because their output voltage is directly proportional to the pickup needle movement rate

equalizers.

Figure 4 is the schematic for a typical octave (graphic) equalizer section. It is similar to the active tone-control circuit shown in Fig. 2, except that *treble control* network consisting of C2, R3, and R4 is fixed rather than variable, and the bass and treble cutoff frequencies are spaced closely. As a result, the two response curves overlap.

Consequently, the circuit in Fig. 4 circuit acts as a narrow-band filter with a center frequency response that is fully variable between +12 dB (full boost) and -12 dB (full cut) by adjusting potentiometer R5.

Figure 5 shows how the circuits of Figs. 3 and 4 are interconnected to form a high quality, ten-band graphic equalizer. The ten equalizer sections

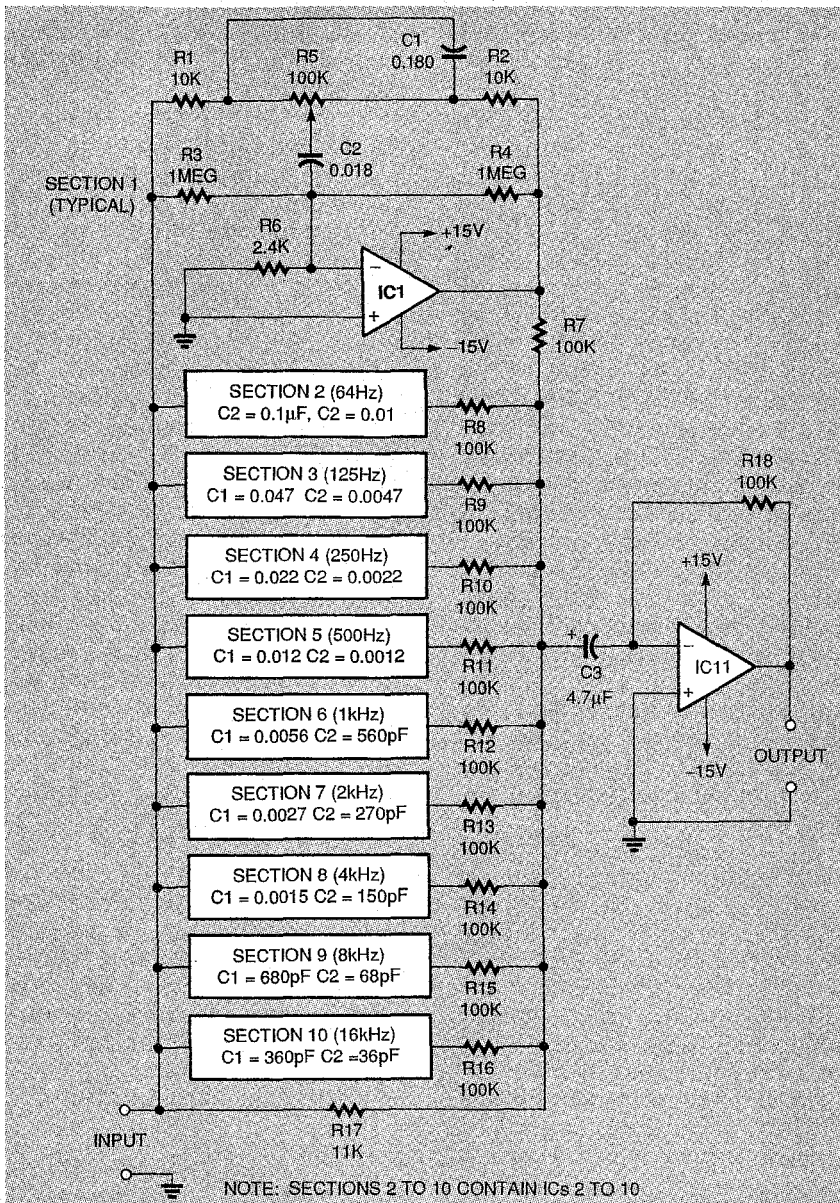

FIG. 5—TEN-OCTAVE (GRAPHIC) equalizer circuit.

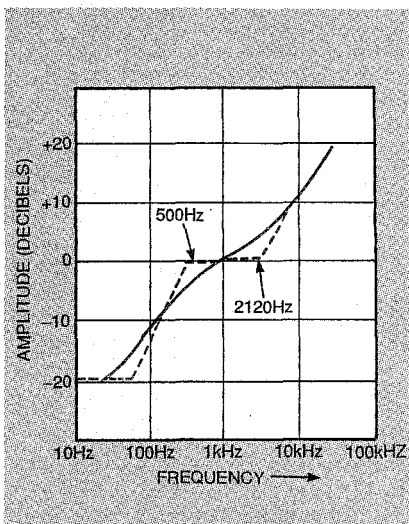

FIG. 6—TYPICAL PHONOGRAPH record playback frequency response curve.

which, in turn, is proportional to recording frequency.

Phono disk recording equipment usually did not provide truly linear frequency response. To enhance the effective dynamic range and signal-to-noise ratio of records, frequencies below 50 Hz and those in the 500-Hz to 2.12-kHz midband range were recorded nonlinearly in accordance with a standard curve defined by the Recording Industry Association of America (RIAA).

This nonlinearity causes a midband drop of 12 dB when the record is played through linear-response ceramic or crystal pickups, but this decrease was too small to be objectionable in

most low-end record players.

Figure 6 shows a plot of a typical phonograph record playback frequency response curve as a solid line and dotted line superimposed on the solid line that represents the ideal response curve. The ideal (dotted-line) curve is flat to 50 Hz where it rises at a 6 dB/octave rate to 500 Hz. It remains flat from 500 Hz to 2120 Hz, then rises again at a 6 dB/octave rate to about 20 kHz.

When a record is played through a magnetic pickup in a high quality hi-fi system, the output of the pickup is pre-amplified before going to the power amplifier. The pre-amplifier must have a frequency equalization curve that is the exact inverse of that shown in Fig. 6, so that an overall linear response is obtained. Figure 7 shows the RIAA equalization

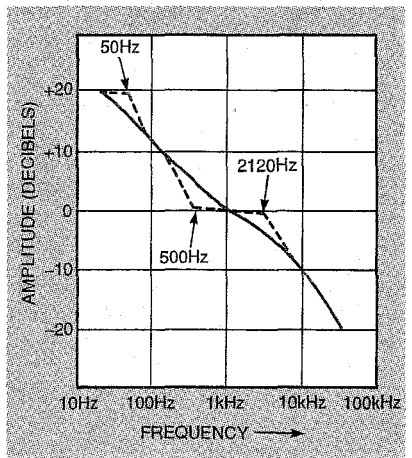

FIG. 7—RIAA PLAYBACK equalization curve.

curve. It is the inverse of recording curve shown in Fig. 6.

RIAA preamplifier

Magnetic pickup cartridges are low-sensitivity devices that give typical midband outputs of only a few millivolts. Consequently, their output signals must be preamplified by a dedicated, low-noise preamplifier integrated circuits rather than general-purpose operational amplifiers. A schematic for a preamplifier with integral RIAA magnetic-pickup equalization is shown in Fig. 8. The circuit includes an LM381 low-noise, dual preamplifier IC.

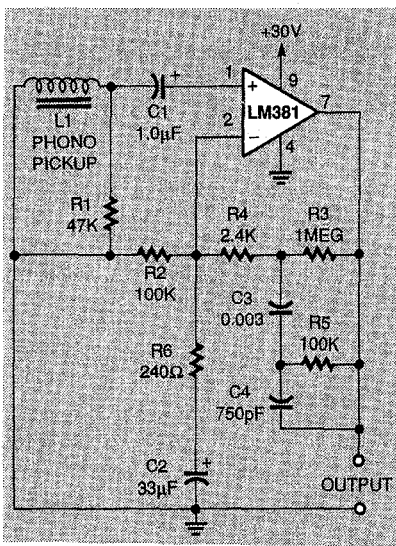

FIG. 8—LOW-NOISE MAGNETIC phono cartridge preamplifier that includes RIAA equalization.

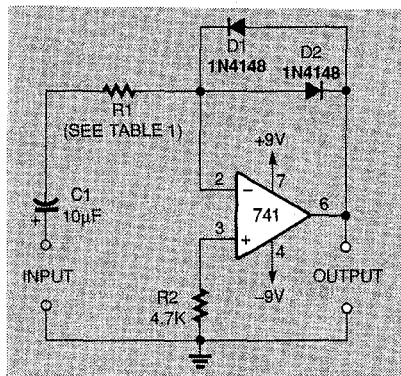

FIG. 9—NONLINEAR (SEMILOG) amplifier based on the 741 operational amplifier.

aged in an 8-pin DIP.) Because two of these preamplifier circuits are needed in a stereo audio system, both sections of the dual preamplifier ICs are used.

The LM381 has a high, open-loop gain of 112 dB, and a total input noise rating of 0.5 microvolts. Its output voltage swing equals the supply voltage minus 2 volts and it has a wide power bandwidth of 75 kHz, 20 volts peak-to-peak. The LM387 is similar to the LM381 except that it has an open-loop gain of 104 dB and a total input noise rating of 1.0 microvolt. The amplifiers in both ICs are electrically independent of each other.

The LM381 in Fig. 8 is configured as a noninverting amplifier. Negative feedback is applied from the output to the inverting input terminal. The voltage divider consisting of resistors R3 and R4, and the network formed by resistor R6 and capacitor C2 determines AC signal gain.

At the audio frequency mid-band (centered on 1 kHz) capacitors C2 and C3 have low impedances and C4 has a high impedance. As a result, AC gain is determined principally by the value of resistor R5 divided by R6, and it equals about 400. At lower frequencies, the impedance of C3 becomes significant

nals form the magnetic pickup cartridge are AC coupled to the LM381 by C1.

Nonlinear amplifiers

An operational amplifier will act as a nonlinear amplifier if a nonlinear component is included in its negative feedback network. Figure 9 shows two square-law response (nonlinear) feedback elements, a pair of diodes connected back-to-back in the feedback loop.

When small signals are applied to this circuit, the diodes act as infinite resistance (open circuits), so circuit gain is high. However, when large signals are applied, the diodes act a low resistances, so circuit gain is low.

The gain follows a semi-logarithmic function, and circuit sensitivity can be varied by altering the value of resistor R1. Table 1 summarizes the circuit performance with two different values of R1—1 and 10 kilohms. For example, it can be seen that a 1000:1 change in input signal amplitude causes a change as small as 2:1 in output level. This characteristic can be put to practical use in single-range bridge-balance detectors and signal-strength indicators. Voltage measurements can be made with an AC millivoltmeter.

When a sinewave input is ap-

TABLE 1
NONLINEAR AMPLIFIER PERFORMANCE

Millivolts (input, RMS)	R1 = 1K		R1 = 10K	
	V _{OUT} mV RMS	V _{GAIN}	V _{OUT} mV RMS	V _{GAIN}
1.0	110	×110	21	×21
10.0	330	×33	170	×17
100.0	450	×4.5	360	×3.6
1000.0	560	×0.56	470	×0.47
10,000.0	600	×0.07	560	×0.56

TABLE 2
CONSTANT - VOLUME
AMPLIFIER PERFORMANCE

R1 = 100K		
Millivolts (input)	V _{OUT} (volts)	V _{GAIN}
500	2.85	×5
200	2.81	×14
100	2.79	×28
50	2.60	×52
20	2.03	×101
10	1.48	×148
5	0.89	×180
2	0.4	×200
1	0.2	×200
0.5	0.1	×200

As an alternative, a National Semiconductor LM387, another low-noise, dual preamplifier will work in the circuit. Both the National LM381 and LM387 are suitable as amplifiers in audio-tape playback preamplifiers.

The pin numbers shown in Fig. 8 are those of the first half of the LM381, packaged in a 14-pin DIP. (The LM387 is pack-

and it causes AC gain to increase until, at very low frequencies, it is limited to 4000 by the ratio of the value of resistor R3 with respect to R6.

By contrast, at high frequencies, the impedance of C4 falls significantly, shunting R5. This causes the AC gain to decrease until, at very high frequencies, it is limited to 10 by the ration of the values of R4 to R6. The sig-

plied to the circuit, the two diodes limit the output voltage swing to about 1.4 volts peak-to-peak by clipping the waveform. The output approximates a

Continued on page 93

AUDIO FILTERS

continued from page 64

square waveform, and it is rich in odd harmonics. If this waveform is amplified, it sounds like a clarinet.

Constant-volume amplifier

The nonlinear amplifier shown in Fig. 9 gives a near constant-amplitude output signal over a wide range of input signal levels, but it does this at the cost of introducing large signal distortion. Figure 10 is a schematic for a *constant-volume* or *constant-amplitude* amplifier that amplifies without distorting the signal. A self-adjusting, voltage-controlled linear network replaces the nonlinear element in the feedback loop of Fig. 9.

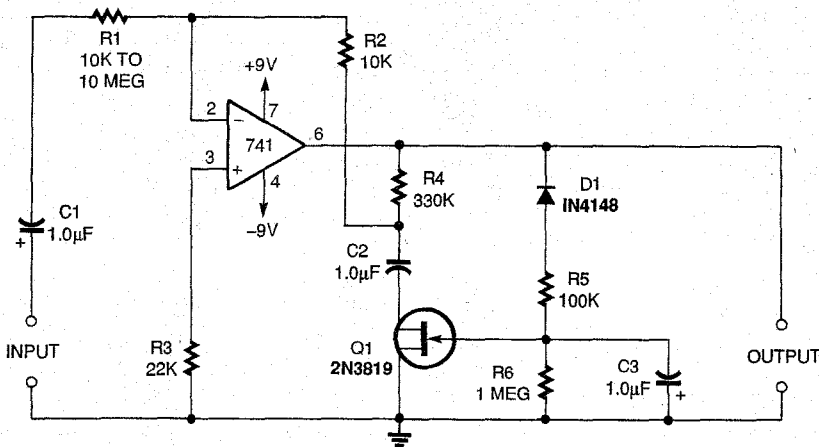

FIG. 10—CONSTANT-VOLUME amplifier that includes a JFET.

The operational amplifier is configured as an AC amplifier with its gain controlled by the ratio of the values of resistor R1 with respect to R2 and by the AC voltage divider formed by R4 in series with the internal impedance of Q1.

This FET functions as a voltage-controlled resistor. Its control voltage is obtained from the output of the operational amplifier with a network formed by diode D1 in series with resistor R5 and resistor R6 in parallel with capacitor C3.

When a small signal is applied to the 741, its output is small. Consequently, very little negative bias is developed on the

FET gate from the network consisting of D1, R5, R6 and C3. The FET functions as a resistance with a value of several hundred ohms. The voltage divider formed from R4 and Q1 causes slight negative feedback that is applied to the 741, so it provides high voltage gain.

By contrast, if a large signal is applied to the 741, its output is large, so a large negative bias is developed on the gate of FET Q1 from the D1, R5, C3 network. As a result, Q1 acts like a very high resistance. In this condition, the R4/Q1 divider applies large negative feedback to the 741, and it provides low voltage gain.

The overall effect of this response characteristic is that the mean level of the output signal is self-regulated at 1.5 to 2.85 volts over a 50:1 range of input

signal level. (This is equal to 500 to 10 millivolts.) It does this without generating audible signal distortion. The circuit's performance is summarized in Table 2.

The value of resistor R1 determines the sensitivity of the circuit. It is selected to accommodate the maximum input signal amplitude that the circuit is expected to handle. This is determined on a basis of 200 kilohms per RMS volt of input signal.

For example, to accommodate a maximum input of 50 volts, R1 should have a value of 10 megohms. Capacitor C3 determines the automatic gain control time constant of the circuit. Ω

MICRO MICON BOARD AKI-80

The AKI-80 is a Z84C015B12 applied (CPU, PIC, CTC, SIO, CGC, etc.), Z80 software-compatible, high-quality 8-bit micon that can be installed in one I/O. The I/O IC is not easily soldered, and has been already installed. AKI-80 <4K SRAM Ver.> \$40.00 AKI-80 <256 SRAM Ver.> \$43.00

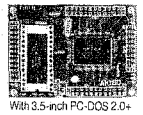

AKI-80 ROM WRITER KIT 1Kit: \$90.00

• Available for use with IBM PC-DOS/3.0 personal computers.
• Corresponds to ROM2764, 27128, 27256
• Internal Z80 developing function.
Contents:
Dedicated board <AKI-80 with gold>
Pin Area ZIF (28 Pin)
D-sub 28
Assembly technology data collection
for ROM WRITER hexabinary software
for IBM PC-DOS/3.0 with 3.5-inch FDD

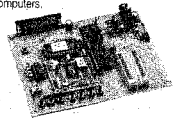

Parallax Development Tools (PIC 16Cxx Microcontrollers)

BASIC Stamp Programming Package \$99.00

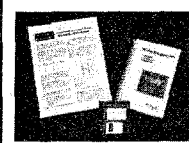

Package includes everything necessary to program Stamps.

PIC 16Cxx Programmer \$188

Programs, reads, and verifies PIC16Cxx devices.

• Supports PIC16C5x, PIC16C71 and PIC16C84

PIC 16C71-84 TrueFlight \$299

Programmer/downloader for PIC16C71/84.

PIC 16C5x Downloader \$299

Acts as ROM emulator for PIC16C5x devices.

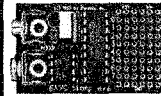

Data Acquisition for your PIC

• ADC-10 \$98.00

(1-channel, 8-bit)

• ADC-12 \$158.00

(1 channel, 12-bit)

0-5V analog input

(with picoscope and picolog,

oscilloscope probes (X1, X10)

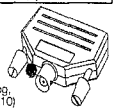

Akizuki Denshi Co., Ltd. was established in 1944, and is currently engaged in the selling of electronic components and electronic measuring instruments in Akinabara, Tokyo. If you are interested in our products, please enclose payment (in \$US) in the amount of the price indicated for and handling costs. We will fill your order and send the product to you as soon as payment is received.

Akizuki Denshi Co., Ltd.

1st Floor, Nomizu Bldg., 1-8-3 Sotokanda, Chiyoda-ku, Tokyo, Japan 101
CALL: 81-3-3431-6279 FAX: 81-3-3251-3357
Supervisor: Akio Tsujimoto

Choose from 46 Career Opportunities!

Get Your Specialized Associate Degree or Career Diploma at Home in Spare Time

Now without attending college classes and with no previous experience, you can train for a money-making career...even get a Degree. Send for free facts and color brochure on employment opportunities in the field that interests you most. See how easy it is to train at home for a great career or advancement in your present job.



CALL TOLL FREE 1-800-595-5505 Ext. 5742
CALL ANYTIME—24 hours a day, 7 days a week.
OR MAIL COUPON TODAY!

ICS International Correspondence Schools
Dept. ADES25S, 925 Oak Street, Scranton, PA 18515

Please send me free facts, color brochure and full information on how I can study at home for the career I have chosen.

No obligation. No salesman will visit. CHECK ONE BOX ONLY!

ASSOCIATE IN SPECIALIZED BUSINESS DEGREE PROGRAMS

- Business Management
- Accounting
- Bus. Mgmt.—Finance Option
- Bus. Mgmt.—Marketing Option
- Applied Computer Science

ASSOCIATE IN SPECIALIZED TECHNOLOGY DEGREE PROGRAMS

- Civil Engineering Technology
- Mechanical Engineering Tech.
- Electrical Engineering Technology
- Electronics Technology
- Industrial Engineering Technology

CAREER DIPLOMA COURSES

- High School
- Motorcycle Repair
- Auto Mechanics
- Catering/Gourmet Cooking
- Surveying and Mapping
- Computer Programming
- Drafting
- Personal Computer Specialist
- Air Conditioning & Refrigeration
- Computer-Assisted Bookkeeping
- Wildlife/Forestry Conservation
- PC Repair
- Fashion Merchandising
- Desktop Publishing & Design
- Diesel Mechanics
- Secretary with Computer
- Electrician
- Fitness & Nutrition
- Small Business Management
- TV/VCR Repair
- Gun Repair
- Animal Care Specialist
- Electronics
- Photography
- Hotel/Restaurant Management
- Journalism/Short Story Writing
- Child Day Care
- Florist
- Legal Assistant
- Teacher Aide
- Interior Decorating
- Medical Office Assistant
- Professional Locksmithing
- Bookkeeping
- Appliance Repair

Name _____ Age _____

Address _____ Apt. # _____

City/State _____ Zip _____

Phone () _____